

INSTALLATION & OPERATION MANUAL

HARMSCO® HURRICANE® FILTERS

HARMSCO® Hurricane® Filters provide exceptionally long filter runs, reduced maintenance and lower filtration costs when used as combination centrifugal separator and cartridge filter or in conventional filtration applications.

HOW THEY WORK

Centrifugal Separation to Remove Dense Particles from Liquids

Liquid enters the Hurricane filter's outer chamber tangentially, producing a rotational flow. This flow pattern creates a centrifugal force which is used to separate dense particles such as sand, rust, grit and metal fines from liquids. Heavy particles drop to the bottom of the filter's outer chamber where they are discharged manually, automatically or continuously. With the dense particles removed, liquid and light solids rise up, over and into an inner chamber where the rotational flow is continued.



Up-flow Cartridge Filtration and Angled Pleats for Lightweight Particle Removal

Trapped air is automatically purged due to principal of up-flow filtration. Filtered liquid exits the filter at the highest point, as it is filtered. A secure top plate prevents cross contamination of filtered and unfiltered liquid. This patented up-flow design allows Harmsco to utilize 100% of cartridge surface area, providing efficient filtration. Filter efficiencies are dramatically improved to provide longer filter runs and reduced filtration costs. Harmsco® Hurricane® filter cartridges for the Waterbetter® filters are available in a wide range of micron ratings and may be cleaned and re-used in most applications and most micron ratings.

Models & Specifications

Three Hurricane® Filter models are available for a wide range of applications. Models and specifications are as follows:

SPECIFICATION	HUR 40 HP	HUR 90 HP	HUR 170 HP
Flow rate (GPM)	Up to 50	Up to 100	Up to 150
Filter area (pleated)	40 sq. ft.	90 sq. ft.	170 sq. ft.
Pipe sizes, inlet & outlet	2" NPT	2" NPT	2" NPT
Pipe size, drain	1" NPT	1" NPT	1" NPT
Filter height	21"	31"	41"
Filter diameter	13"	13"	13"
Floor space required	15"x15"	15"x15"	15"x15"
Service height clearance	31"	51"	72"
Shipping weight (approx.)	40 lbs.	51 lbs.	64 lbs.
Temperature rating*	140° (60°C)	140° (60°C)	140° (60°C)

*Varies based on pressure and time under load.

Features

Product features include:

- 304 stainless steel filter housings
- Electro-polished for superior finish
- Resistant coatings available
- Fail-safe lids with individual studs for security
- Brass wing-nuts for convenience
- 90° elbow and 45° sweep on outlet for in-line vertical installation
- CPVC standpipe for up-flow design
- Choice of cartridges available



HUR 40 HP

HUR 90 HP

HUR 170 HP

Temperature & Pressure Ratings

Hurricane® Filters are rated for pressures to 150 psi and temperatures to 140°F.

Sizing

Use the chart shown below to size Hurricane® Filters for your application:

Flow Rate	Recommended Model	Pleated Filter Area
Up to 50 GPM	HUR 40 HP	40 sq. ft.
Up to 100 GPM	HUR 90 HP	90 sq. ft.
Up to 150 GPM	HUR 170 HP	170 sq. ft.
Up to 300 GPM	HUR 170 HP (two filters*)	340 sq. ft. (two filters*)
Up to 450 GPM	HUR 170 HP (three filters*)	510 sq. ft. (three filters*)
Up to 600 GPM	HUR 170 HP (four filters*)	680 sq. ft. (four filters*)
Up to 750 GPM	HUR 170 HP (five filters*)	850 sq. ft. (five filters*)

*Parallel installation with valves to isolate filters for service while other filters are operational.

Pressure Drop

The total head loss data shown below was developed by NSF International and indicates pressure drop with Hurricane® Filter and one micron filter cartridge in clean water.

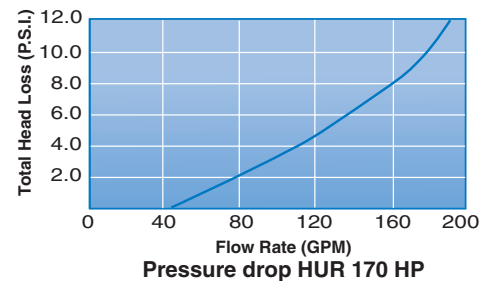
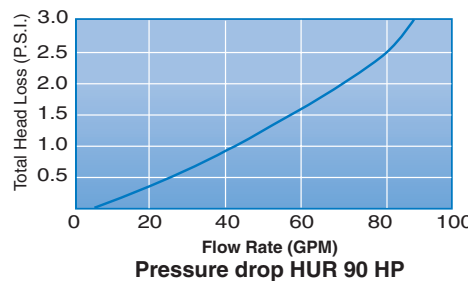
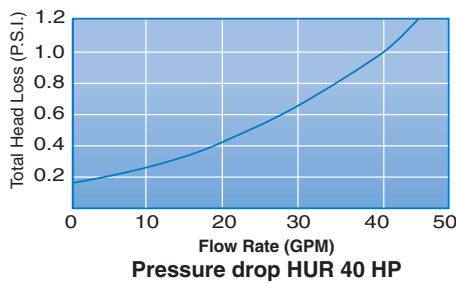

Harmsco® Hurricane® Replacement Cartridges

Hurricane® replacement cartridges are available in a wide range of nominal ratings, shown right.

Cartridges are rated for temperatures to 140°F and may be used to separate solids in liquids with a pH of 3 to 11.

Packaged one cartridge per carton.



Filter Model	Cartridge Product Code	Nominal Micron	Cartridge Dimensions			Ship Wt./Ctn. (One Cartridge)
HUR 40 HP	HC/40-0.35	0.35	9 5/8"	7 3/4"	3" FPT	4 lbs.
	HC/40-1	1	9 5/8"	7 3/4"	3" FPT	4 lbs.
	HC/40-5	5	9 5/8"	7 3/4"	3" FPT	4 lbs.
	HC/40-10	10	9 5/8"	7 3/4"	3" FPT	4 lbs.
	HC/40-20	20	9 5/8"	7 3/4"	3" FPT	4 lbs.
	HC/40-50	50	9 5/8"	7 3/4"	3" FPT	4 lbs.
	HC/40-100	100	9 5/8"	7 3/4"	3" FPT	4 lbs.
	HC/40-150	150	9 5/8"	7 3/4"	3" FPT	4 lbs.
HC/40-EZ-CLEAN	NR*	9 5/8"	7 3/4"	3" FPT	4 lbs.	
HUR 90 HP	HC/90-0.35	0.35	19 1/2"	7 3/4"	3" FPT	7 lbs.
	HC/90-1	1	19 1/2"	7 3/4"	3" FPT	7 lbs.
	HC/90-5	5	19 1/2"	7 3/4"	3" FPT	7 lbs.
	HC/90-10	10	19 1/2"	7 3/4"	3" FPT	7 lbs.
	HC/90-20	20	19 1/2"	7 3/4"	3" FPT	7 lbs.
	HC/90-50	50	19 1/2"	7 3/4"	3" FPT	7 lbs.
	HC/90-100	100	19 1/2"	7 3/4"	3" FPT	7 lbs.
	HC/90-150	150	19 1/2"	7 3/4"	3" FPT	7 lbs.
HC/90-EZ-CLEAN	NR*	19 1/2"	7 3/4"	3" FPT	7 lbs.	
HUR 170 HP	HC/170-0.35	0.35	30 3/4"	7 3/4"	3" FPT	10 lbs.
	HC/170-1	1	30 3/4"	7 3/4"	3" FPT	10 lbs.
	HC/170-5	5	30 3/4"	7 3/4"	3" FPT	10 lbs.
	HC/170-10	10	30 3/4"	7 3/4"	3" FPT	10 lbs.
	HC/170-20	20	30 3/4"	7 3/4"	3" FPT	10 lbs.
	HC/170-50	50	30 3/4"	7 3/4"	3" FPT	10 lbs.
	HC/170-100	100	30 3/4"	7 3/4"	3" FPT	10 lbs.
	HC/170-150	150	30 3/4"	7 3/4"	3" FPT	10 lbs.
HC/170-EZ-CLEAN	NR*	30 3/4"	30 3/4"	3" FPT	10 lbs.	

Activated carbon and Poly-Pleat Hurricane® cartridges available. Please see catalog.

* NR - not rated

Cartridge Cleaning Instructions

Hurricane® cartridges are made of Polyester Plus™, a proprietary blend of polyester fibers which can be cleaned in most applications and micron ratings to make Hurricane® filter elements reusable! For best results, follow the directions described below:

When Cartridge Cleaning is Possible

Clean cartridge when pressure differential is 12 psi above startup differential.

Non-cleanable Applications

Replace cartridge when pressure differential is 30 psi above start-up differential or when flow has diminished to an unacceptable level, indicating cartridge is at capacity.

Cartridge Removal

To remove filter cartridge, drain filter housing. Remove wing-nuts and lid. Hold cross-bar in retainer nut and pull upward to remove filter cartridge and top plate from filter housing. Follow cleaning instructions described herein.

Lid Replacement

Replace wing-nuts systematically, rotating around filter. "Finger tight" is normally sufficient. However, in extreme duty applications it may be necessary to tighten to 75 inch lbs. of torque. Over-tightening can cause damage to the rim gasket.

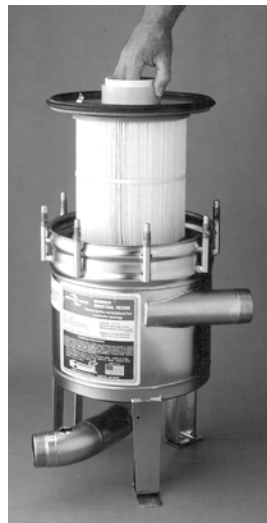

Cartridge Cleaning in Aqueous Applications

For best results, clean cartridges with pressure nozzle using standard hose. Direct spray at an angle to remove particulate (see photo). Follow these directions to remove oils, organic matter, algae and mineral deposits.



Caution: Do not rinse cartridges with acid until oils and organic matter are removed. Use detergent first and follow with acid bath for mineral removal. Flush cartridges with water after muriatic or tri-sodium phosphate baths.

OILS: Soak cartridge in a solution of tri-sodium phosphate or similar strong detergent (2 lbs. to 10 gallons of water). Soak up to 12 hours for best results. Rinse after bath.

ORGANIC MATTER, ALGAE: Use tri-sodium phosphate solution as described above, plus 1 pint of liquid chlorine to kill organic matter and algae. Soak cartridge one hour or longer until surface is no longer "slippery." Rinse after bath.

CALCIUM MINERAL DEPOSITS: Follow directions for "oils" described above. Soak cartridge for approximately ten minutes in a solution of one part of muriatic acid to twenty parts of water. Rinse cartridge thoroughly with water.

When Cartridge Cleaning is Not Possible

Generally, it is not possible to clean Hurricane® filter cartridges when filtering petroleum-base liquids, toxic substances, and one and below micron applications.

Note: Pressure gauges are recommended to indicate when cartridge cleaning or replacement is necessary.

Model	A Height	B Width	C Diameter	D Inlet	E Outlet
HUR 40 HP	19 1/2"	14 5/8"	13"	12 3/4"	3 7/16"
HUR 90 HP	29 7/8"	14 5/8"	13"	17 3/4"	3 7/16"
HUR 170 HP	40 1/2"	14 5/8"	13"	23 5/8"	3 7/16"

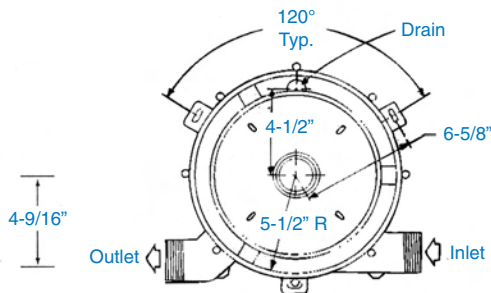

Pressure Gauges

Install optional pressure gauges in gauge ports as shown above. Use pressure differential to indicate when to clean or replace cartridge.

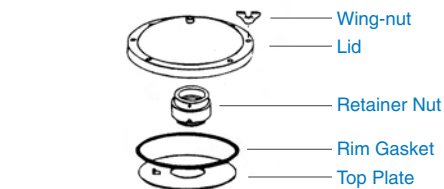
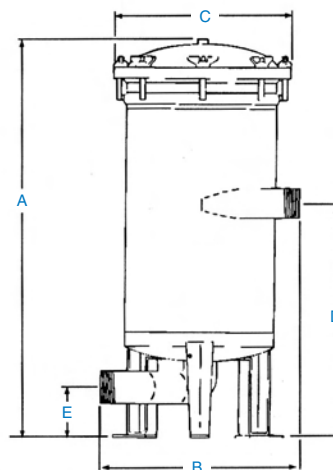

Cartridge Sub-assembly

Prior to installing cartridge in filter, place top plate on top of cartridge with clip upward. Thread on retainer nut securely for proper seal.

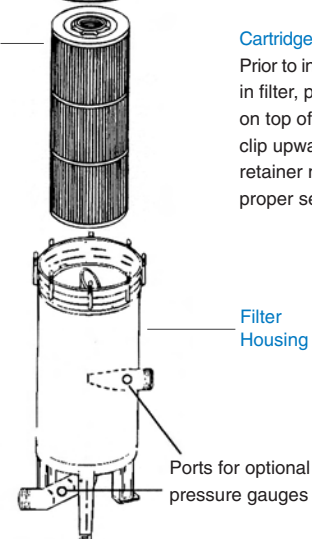

Installation

Install filter using 2" couplers for inlet and outlet with 1" coupler for drain pipe. Shut-off valves should be installed on inlet, outlet and on drain pipe to be able to service the filter and isolate it when necessary.

Pressure gauges are also recommended before and after the filter to easily calculate the pressure differential and to know when cartridge should be cleaned or replaced. Threaded flanged fittings for inlet and outlet are available by special order.

1/4" FPT Lid Fitting

One-quarter inch FPT fittings are installed in Waterbetter® Filter lids for a number of customer supplied options, including petcock for pressure relief, pressure gauge, sensor, thermocouple, etc. This fitting should be plugged at time of installation if one of these options is not installed.



Harmsco, Inc. Industrial Filters Limited Warranty

- Harmsco, Inc. warrants its line of Industrial Filters to be free of defects in material and workmanship for a period of one year from the date of installation.
- The warranty for Industrial Filters ordered with special coatings is limited only to the recoating of the defective parts due to failure in materials or workmanship for one year from date of installation.
- This warranty does not cover any equipment purchased for use in applications in which the product is not suited. It is the responsibility of the buyer to determine if a product is suitable for a particular application.
- THIS WARRANTY EXCLUDES THE FOLLOWING:
 - Any fresh water unit installed for salt water use.
 - Damage caused by improper installation, operation or care.
 - Chemical attack.
 - Rubber type parts and normal wear items, i.e. "o" rings, rim gaskets, wing nuts, pipe caps, holding rods.
 - Any costs of labor or expenses incurred in the removal and/or installation of Unit, or any surrounding device.
 - Damage caused by galvanic or electrolytic attack.
 - Altering or removing the Harmsco, Inc. information label.
 - Any unit not grounded.
- Service under this warranty is to be provided by the dealer/distributor who sold the unit to the distributor. If the dealer/distributor is unable to provide warranty service, contact:

Harmsco, Inc. P.O. Box 14066
North Palm Beach, Florida 33408, U.S.A.
Phone (561) 848-9628 • Fax (561) 845-2474

A Returned Goods Authorization (RGA) number must be received from the above office and placed on all shipments to and correspondence with Harmsco, Inc. Please be prepared with the following information:

- Model number and serial number
- Date of installation
- Name of installer
- Nature of problem
- Your address and telephone number.

Particle Separation

Particle separation with Hurricane® filters is influenced by particle weight and flow rate. For optimum separation, the drain valve should be opened routinely by hand or automatically using a timer actuated valve. Automatic purge valves are not available from Harmsco. However, for more information regarding this equipment, please contact the Authorized Harmsco Distributor in your area.

The data shown below was developed through tests conducted with Hurricane® filters and twenty micron filter cartridges to determine optimum flow rates for particle separation. Sand was used as the test's particulate with a specific gravity of 2.6 relative to water at 1.0. This data is provided for general sizing purposes only. Results vary and depend on the particulate being filtered, viscosity and other variables.

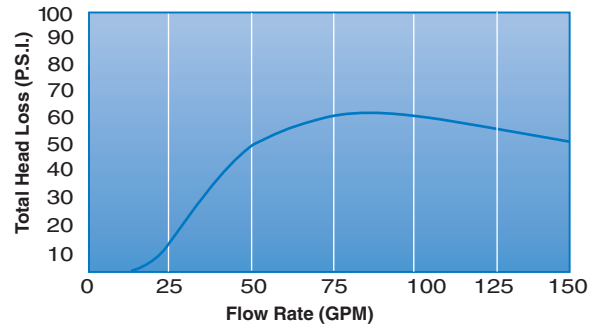

Tests indicate the separation of performance of all three Hurricane® filters were essentially the same up to the rated flow rate of each model.

Part List

Hurricane® Filter parts and components are listed below:

Part No.	Material	Description
550-E	EPDM	Rim gasket to seal filter
905-P	PVC	Retainer nut for filter cartridge
309SS	Stainless steel	Top plate
312	PVC	Retainer nut insert
530-AC	Stainless steel	Lid with vent
316-C	CPVC	Standpipe for HUR 40 HP
317-C	CPVC	Standpipe for HUR 90 HP
315-C	CPVC	Standpipe for HUR 170 HP
202-B	Brass	Wing-nut
329	CPVC	Inner vessel isolator
330	Stainless steel	Screw 1/4" x 1/2" for isolator

Options:

550-B	Buna-N	Rim gasket to seal filter
550-V	Viton	Rim gasket to seal filter
327	Stainless steel	2" Flange fittings (set of 2)

Available From:



HARMSCO® Filtration Products

P.O. Box 14066 • North Palm Beach, FL 33408
800.327.3248 • 561.848.9628 • Fax: 561.845.2474 • E-mail: sales@harmsco.com

www.harmsco.com

